

*Anup Mazumder*  
Anup Mazumder (Mar 4, 2021 11:55 CST)

Mar 4, 2021



*L. Pettigrew*

Mar 4, 2021

SCHNEIDER ENGINEERING, LLC



# SPECIFICATION FOR GENERATOR STEP-UP POWER TRANSFORMER

PREPARED FOR:  
**TOLEDO BEND PROJECT JOINT OPERATION**  
SABINE RIVER AUTHORITY OF TEXAS  
SABINE RIVER AUTHORITY OF LOUISIANA

MARCH 4, 2021

REVISION	DATE	DESCRIPTION
0	1/14/2021	ISSUED FOR FINAL REVIEW
1	3/4/2021	UPDATED SECTIONS 10.03.08, 10.04.01,11.04,12,13,14 AND APPENDIX B

**SPECIFICATION FOR  
GENERATOR STEP-UP POWER TRANSFORMER**

**TABLE OF CONTENTS**

**1.00    ITEM ..... 3**

**2.00    SCOPE ..... 3**

**3.00    USE ..... 3**

**4.00    APPLICABLE STANDARDS..... 3**

**5.00    GENERAL..... 5**

**6.00    RATINGS ..... 7**

**7.00    CONSTRUCTION .....10**

**8.00    DRAWINGS AND INSTRUCTION MANUALS .....39**

**9.00    INSPECTIONS-TESTS .....43**

**10.00    SHIPPING .....48**

**11.00    SERVICING AND ASSEMBLY .....52**

**12.00    APPROVED BIDDER .....53**

**13.00    BID PROPOSAL .....53**

**14.00    REJECTION.....53**

**15.00    INVOICE .....54**

**16.00    WARRANTY .....54**

**17.00    DISCLAIMER .....55**

**18.00    SPARE PARTS.....55**

**APPENDIX A ..... A-1**

**APPENDIX B..... B-1**

**SPECIFICATION FOR  
GENERATOR STEP-UP POWER TRANSFORMER**

**1.00 ITEM: TRANSFORMER, GSU**

Generator Step-up Power Transformer

**2.00 SCOPE:**

This specification covers the design, construction, testing, inspection, shipping, installation, performance and warranty of two new three phase generator step-up power transformers and accessories for a Hydroelectric generating station and factory set to operate at the following voltages:

Item	Quantity	MVA Rating (55°/65°C)	Voltage Range	Initial Operation
1	2	30/40/50//56	13.8 kV – 138 kV Delta Wye	Fall, 2022

- 2.01 Delivery date for the first unit shall be no later than 48 weeks ARO (Including Final Site Assembly and Testing) and 52 weeks for the second unit.
- 2.02 All materials, construction and characteristics shall be in accordance with the latest applicable standards of IEEE and ANSI as listed in Section 4.00 and be UL, or by a NRTL, certified and labeled.
- 2.03 All electrical equipment and systems proposed shall be approved by the owner or the owner’s representative for installation at the project site.

Delivery Address:  
**Sabine River Authority Powerhouse**  
**450 Spur 135**  
**Burkeville, Texas 75932**

**3.00 USE:**

This equipment is to be used for three phase, 60 hertz voltage conversion in an outdoor substation in East Texas area.

**4.00 APPLICABLE STANDARDS:**

**4.01 Industry Standards**

Each of the following specific standards or the latest revision thereof shall become a part of this specification as well as any standard or part thereof referred to therein.

- 4.01.01** American National Standards Institute (ANSI) CGA V-1 - Compressed Gas Cylinder-Valve Outlet and Inlet Connections

- 4.01.02** ANSI C29.9 – Wet Process Porcelain Insulators – Apparatus, Post Type
- 4.01.03** ANSI C57.12.00 - General Requirements for Distribution, Power, and Regulating Transformers
- 4.01.04** ANSI C57.12.10 - Requirements for Transformers 230,000 Volts and below, 833/958 through 8333/10,417kVA, Single Phase, and 759/862 through 60,000/80,000/100,000 kVA, Three Phase
- 4.01.05** ANSI C57.12.70 - Terminal Markings and Connections for Distribution and Power Transformers
- 4.01.06** ANSI C57.12.80 – Terminology for Power and Distribution Transformers
- 4.01.07** ANSI C57.12.90 - Test Code for Distribution, Power, and Regulating Transformers
- 4.01.08** ANSI C57.13 - Requirements for Instrument Transformers
- 4.01.09** ANSI C57.19.00 - General Requirements and Test Procedure for Outdoor Power Apparatus Bushings
- 4.01.10** ANSI C57.19.01 - Standard Performance Characteristics and Dimensions for Outdoor Apparatus Bushings
- 4.01.11** ANSI C57.92 – Guide for Loading Oil Immersed Distribution and Power Transformers
- 4.01.12** ANSI C57.98 - IEEE Guide for Transformer Impulse Test
- 4.01.13** ANSI C57.106 - Guide for Acceptance and Maintenance of Insulating Oil in Equipment
- 4.01.14** ANSI C57.116 - Guide for Transformers Directly Connected to Generators.
- 4.01.15** ANSI C57.131 - Requirements for Tap Changers
- 4.01.16** ANSI C57.148 – IEEE Standard for Control Cabinets for Power Transformers
- 4.01.17** ANSI C62.11 - Standard for Metal-Oxide Surge Arresters for Alternating Current Power Circuits
- 4.01.18** ANSI C62.22 - Standard Guide for the application of Metal-Oxide Surge Arresters for Alternating-Current Systems
- 4.01.19** Institute of Electrical and Electronic Engineers (IEEE) STD 4 - Standard Techniques for High Voltage Testing
- 4.01.20** IEEE 80 - Guide for Safety in Substation Grounding
- 4.01.21** IEEE Accredited Standards Committee C2-2002\_ National Electric Safety Code
- 4.01.22** NEMA Standard Publication No. TR-1 for Transformers, Regulators, and Reactors

- 4.01.23** NEMA 250 – Enclosures for Electrical Equipment
- 4.01.24** NEMA CC1 – Electric Power Connectors for Substations
- 4.01.25** NEMA ICS2 – Standards for Industrial Control Devices, Controllers and Assemblies
- 4.01.26** NFPA 70 – National Electric Code (NEC)
- 4.01.27** ASTM A153-95 Specification for Zinc (Hot-Dip Galvanized) Coatings on Iron and Steel Products
- 4.01.28** ASTM D877 – Di-electric Breakdown Voltage of Insulating Liquids Using Disk Electrodes
- 4.01.29** ASTM D923 – Sampling Electrical Insulating Liquids
- 4.01.30** ASTM D1816 – Di-electric Breakdown Voltage of Insulating Oils of Petroleum Origin using VDE Electrodes
- 4.01.31** ASTM D3487 – Mineral Insulating Oil Used in Electrical Apparatus

**5.00 GENERAL:**

**5.01 Design**

- 5.01.01** The requirements specifically stated herein shall govern should there be any conflict with the above standards or the references therein. The Engineer shall be apprised of all discrepancies for resolution.
- 5.01.02** The design life of the transformer shall be 30 years and shall be designed for operation in an ambient temperature of 40 degree C maximum, 30 degree C average over a 24 hour period per IEEE Standards (*unless noted differently.*)

**5.02 N/A**

**5.03 Service Conditions**

- 5.03.01** The transformer shall be suitable for operation at its rated kVA for the usual temperature and altitude service conditions as defined in ANSI C57.12.00 and as stated below.

Elevation: <3300 feet above Mean Sea Level

Maximum Ambient Design Temperature: 40 °C

Minimum Ambient Design Temperature: -20 °C

Seismic Rating: As per geological and geographical location of Toledo Bend, TX

Service: Continuous

#### **5.04 Losses**

- 5.04.01** The design shall be for the most economic loss ratio (conductor loss/core loss).
- 5.04.02** The guaranteed maximum losses will be used in an economic evaluation of the Manufacturer's proposal. The criteria for evaluation may be found in Appendix A, item 10.01. Supplier agrees to compensate Buyer for no load and load losses
- 5.04.03** The manufacturer shall provide the auxiliary equipment power losses.

#### **5.05 Rating**

Specific ratings will be found in Section 6.00 of this specification. The following general conditions apply.

- 5.05.01** The transformer should use thermally upgraded insulation and be dual rated for both 55C and 65C rise. The transformer nameplate shall indicate both capacity ratings.
- 5.05.02** The kVA capability of transformer at a 65 degrees Centigrade rise shall be 112% of the 55 degrees Centigrade rise rating.

#### **5.06 Loading**

Transformer shall be capable of emergency overload conditions per ANSI C57.92. The appurtenances such as bushings, bushing leads and load tap changer shall not limit this overload capacity. It is understood that there will be some loss of life associated with this overload condition. That loss of life should be approximated using ANSI C57.92.

- 5.06.01** Operating continuously at no load at 110 percent, or as specified, of any available tap rated output voltage without exceeding the average temperature rise by resistance.
- 5.06.02** Operating continuously at maximum rated load at 105 percent, or as specified, of any available tap rated output voltage without exceeding the average temperature rise by resistance.
- 5.06.03** The transformer shall be designed and constructed to allow "Planned Loading Beyond Nameplate" in accordance with IEEE C57.91 "IEEE Guide for Loading Mineral-Oil-Immersed Transformers". Planned Loading Beyond Nameplate will not exceed 125 percent of the maximum rating of any winding.

#### **5.07 Short Circuit Strength**

- 5.07.01** The transformer shall meet or exceed the requirements of ANSI C57.12.00, Section 7, Short-Circuit Characteristics, limited to two seconds.

**5.07.02** The Manufacturer shall also show evidence that their design will meet or exceed the requirements stated in 5.07.01 by either:

- (1)** Submitting certified test reports covering two fully offset shorts per phase at rated voltage with the short circuit current limited only by the transformer impedance on a prototype unit, or
- (2)** Submitting data and drawings showing that the successful short circuit strength design has been accomplished.

**5.07.03** The transformer shall be self-protecting without the aid of external impedance from a through fault standpoint. These design criteria shall apply to the primary and secondary windings.

**5.07.04** All transformer parts shall be adequately sized, insulated and braced to meet the short circuit requirements of IEEE Standard C57.12.00 and to withstand the short circuit test code as defined in IEEE Standard C57.12.90.

**5.07.05** The audible sound level of the transformer shall not exceed the average sound levels specified in Table O-2 of NEMA Standard TR1-1993 or latest revision.

#### **5.08 Impedance**

See 6.00 below.

### **6.00 RATINGS**

#### **6.01 Voltage Rating**

**6.01.01** The specific voltage ratings for transformers covered by this specification are to be provided according to Table 6.1.

#### **6.02 Capacity Rating**

**6.02.01** The 55/65 degrees Centigrade temperature rise capacity ratings for transformers included in this specification are to be provided according to Table 6.1.

**TABLE 6.1 - POWER TRANSFORMER RATINGS**

Item	Required Delivery Date		H	Ho	X
1	See 2.01	VOLTAGE (kV)	138 Grd Wye		13.8 Delta
		Winding BIL (kVp)	550	150	150
		Bushing BIL (kVp)	650	150	150
		CT's	600:5 MR Relaying (1) 300:5/600:5DR Metering (1) 1200:5MR Relaying (1)	800:5 MR Relaying (1)	3000:5MR Relaying (3)
		ARRESTERS, MCOV (kV)	88		8.4
		ONAN/ONAF/ONAF (MVA) @ 55/65°C temperature rise	30/40/50//56		
		Impedance @ 30 MVA	9.5%		

**Notes to Table 6.1:**

1. Quantities of current transformers per phase are indicated in parenthesis.
2. All Relaying Current Transformers shall be C800, Multi-Ratio.
3. All Metering Current Transformers shall have 0.3 accuracy, 1.8 burden, 2.0/1.5 RF.
4. CT Placement sequence on lead from winding to bottom of H bushing (from bottom to top) is relay, metering.
5. Purchaser's auxiliary voltages shall be 120/240 VAC, 3 wire, single phase and 125 VDC, unless otherwise specified.

**6.02.02** The following types of cooling for transformers are allowed (Self-cooled/Forced-cooled First Stage/Forced-cooled Second Stage):

- ONAN/ONAF/ONAF



**6.03 Bushing Current Transformers**

**6.03.01** All relaying current transformers shall be multi-ratio (five tap) and the proper ratio of the bushing current transformers corresponding to each voltage and capacity shall be provided according to Table 6.1, of this specification.

**6.03.02** The bushing current transformers required shall be internal to the tank and shall meet the requirements of Section 7.16 of this specification.

**6.04 Basic Impulse Level (BIL) Rating**

**6.04.01** The BIL corresponding to each voltage rating included in this specification shall be as specified in Table 6.1.

**6.04.02** The BIL for the Ho lead and bushing for Delta-Wye connected transformers shall be the same as that for the other H windings and bushings for that transformer.

**6.04.03** N/A

**6.05 Surge Arrester Ratings**

**6.05.01** The following station class metal oxide gapless surge arresters have been approved for use on Purchaser’s 60 Hz, three-phase solidly grounded neutral electric transmission and distribution system:

**Table 6.2 Surge Arresters**

Nominal (L-L) (kV) RMS	Manufacturer	Duty Rating (kV)	MCOV (kV)	Type
138	Hubbell	108	88	EVP / MVN
	ABB	108	88	EXLIM-Q / XPS
	GE	108	88	TRANQUELL
13.8	Hubbell	10	8.4	EVP / MVN
	ABB	10	8.4	EXLIM-Q / XPS
	GE	10	8.4	TRANQUELL

**(1)** The station class arrester pressure relief capability shall be 65 kA RMS (symm), min.

**(2)** Surge arresters shall be station class and provided according to the details of Table 6.1.

**(3)** The surge arresters shall be provided with an Anderson TLS-42 connector for grounding purposes. No substitutions permitted on the ground connector.

**6.05.02** The rating of the surge arrester corresponding to each voltage rating included in this specification shall be as specified in Table 6.2.

## 6.06 Additional Tap Voltages

### 6.06.01 De-energized Tap Changer

- (1) The H winding of all transformers shall have a full capacity De-energized Tap Changer unless otherwise specified. This shall be provided according to Section 7.14 of this specification.
- (2) The tap changer shall have two (2) 2 1/2% steps above and two (2) 2 1/2% steps below nominal rated voltage.
- (3) The tap changer shall be capable of carrying the full transformer short circuit current without damage or contact separation.

## 7.00 CONSTRUCTION:

The transformer shall be constructed with the following features:

### 7.01 Bushings

The insulation class of the bushings required shall be as specified in Section 6.04.

**7.01.01** The electrical and dimensional characteristics of apparatus bushings shall be as specified for the appropriate insulation class in ANSI C76.1 and C76.2.

**7.01.02** Bushings shall be cover mounted and located as specified in Figure 7.1 (see next page). LV bushings shall be provided with flanged provisions to interface with existing 2000A cable bus.

**Manufacturer shall provide in Segment I, side mounted LV phase bushings enclosed in a partial height Air Terminal Chamber with provisions to connect three (3) per phase, 750MCM cables.**

**7.01.03** Each bushing shall be provided with a stud connector having a NEMA 4" x 4", four-hole Cadmium, silver or tin plated pad.

**7.01.04** A neutral bushing shall be furnished for all Wye connected three-phase windings for connecting to the neutral of the windings.

**7.01.05** All bushings shall be ANSI Sky Gray #70 colored porcelain.

**7.01.06** All bushings of the same voltage class provided on the same order shall be electrically and mechanically identical.

**7.01.07** All bushings shall be manufactured by ABB type "O Plus C", and have C1 and C2 test taps. C1 power factor shall not exceed 0.5% and the C2 power factor shall not exceed 1%. Test results shall be recorded as referenced in specification item 9.01.01 paragraph m.

Bushings shall be: X- 25kV Class 3000A  
H and H0- 145kV Class 800A

**7.01.08** The minimum phase-to-phase spacing of any two bushings shall not be less than 24", unless approved by Purchaser.

**Figure 7.1 Bushing Layout**

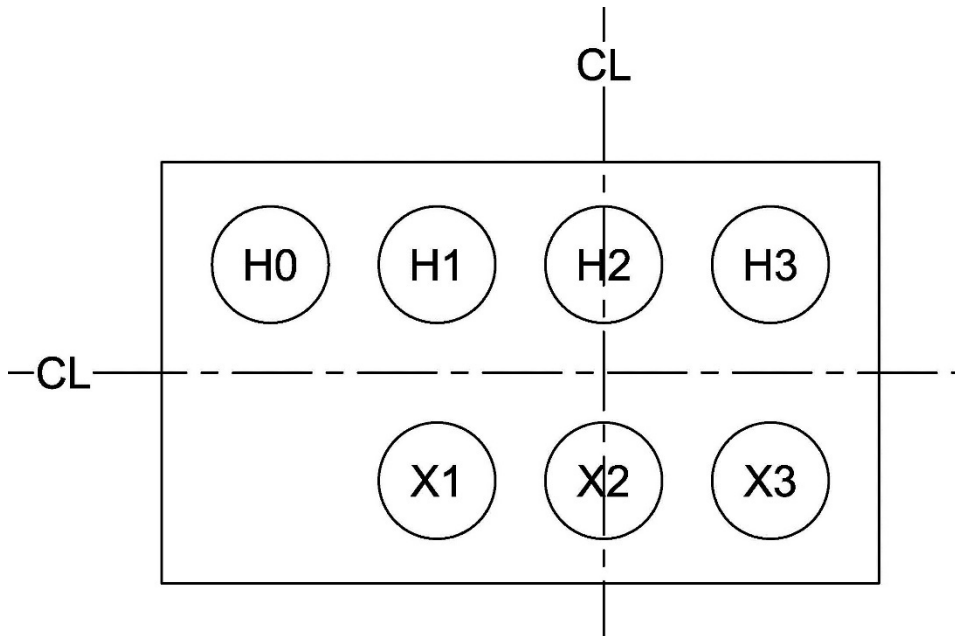

**7.02 Liquid-Level Indicator**

A magnetic liquid-level indicator shall be readable while standing at the base level, and shall be manufactured by Qualitrol.

**7.02.01** The indicator shall have a dark face dial with light colored markings and a light colored indicating hand.

**7.02.02** The diameter of the dial (inside bezel) shall not be less than:

- (1) 3 1/4", when the center of the indicator dial is 96" or less above the base.
- (2) 5 1/2", when the center of the indicator dial is more than 96" above the bottom of the base.

**7.02.03** Dial markings shall show the 25 degrees Centigrade level and the "Hi-Lo" levels.

**7.02.04** The words "liquid level" shall be on the dial or on a suitable nameplate adjacent to it.

**7.02.05** The 25 degrees Centigrade liquid level shall be indicated by suitable permanent markings on the tank or by indicating the distance from the liquid level to the highest point of the hand-hole or manhole flange surfaces on the nameplate.

**7.02.06** The change in liquid level per 10 degrees Centigrade change in temperature shall be indicated on the nameplate.

**7.02.07** Liquid level indicators mounted above 96" from Transformer base shall have their dial face tilted downwards for ease of viewing, unless specified otherwise.

**7.02.08** Alarm contacts shall be available for one 'HI' and two 'LOW' oil levels – Low and Critically low.

**7.02.09 Alarm Contacts**

(1) Alarm contacts shall be available for one "HI" and two "LOW" system points: Low and Critical Low.

(2) Non-grounded minimum-level alarm contacts shall be provided, suitable for interrupting, at 250 Vdc, a maximum of:

(a) 0.02 amperes direct-current inductive load

(b) 0.20 amperes direct-current non-inductive load

(3) These alarm contacts and any additional or spare contacts shall be brought out as individual alarms and terminated in the control cabinet on a properly labeled (description and whether Normally Open **NO**, or Normally Closed **NC**) terminal block for alarms.

(4) The terminal block shall meet the requirements of Section 7.09.04 and 7.09.05 herein.

(5) The wiring for the alarm contacts shall meet the requirements of Section 7.21, Auxiliary Wiring, herein.

**7.03 Thermometer (Top-Oil)**

**7.03.01** A bulb-type thermometer for indicating the liquid temperature shall be mounted in a thermometer well as shown in ANSI C57.12.00, Figure 3. Thermometer shall be manufactured by Qualitrol.

**7.03.02** The indicator shall be remote mounted at eye level height. All capillary tubing shall be protected from mechanical damage.

**7.03.03** The thermometer shall have a dark face dial with light colored markings, a light colored indicating hand, and an orange-red maximum indicating hand with provisions for resetting.

**7.03.04** The diameters of the dial (inside bezel) shall be 3 ½" minimum.

- 7.03.05** Switch settings shall be visible and accessible for adjustment from the bezel face after removal of the cover glass. The indicator shall be ambient temperature compensated and have a 2% accuracy over the dial range.
- 7.03.06** The dial markings shall cover a minimum range of 0 degrees Centigrade to 160 degrees Centigrade with a minimum of 5 degrees Centigrade graduations.
- 7.03.07** The words "liquid temperature" shall be on a suitable nameplate mounted adjacent to the thermometer.
- 7.03.08** Non-grounded alarm contacts shall be provided per Section 7.02.07 of this specification.
- 7.03.09** Gauge capillary shall be protected with a continuous Stainless Steel armor.

#### **7.04 Sudden Pressure Relay**

- 7.04.01** One (1) Qualitrol rapid pressure rise (RPRR) sudden pressure relay are to be furnished for alarm-trip circuit closing on occurrence of a fault in the transformer, which produces an abnormal rise of pressure.
- 7.04.02** This relay shall consist of a pressure tight case in which is mounted a bellows operated microswitch, a seal-in relay, equalizer, and a test plug.
- 7.04.03** A Qualitrol seal-in relay shall be provided per sudden pressure relay. The voltage rating of the seal-in relay shall be 125 VDC. Sudden (fault) pressure relay circuits will be powered with 125 VDC from customer's lockout relay circuit. Contacts from the relays shall be connected in series and will be used by the Owner for tripping circuit breakers. Non-grounded alarm contacts shall be provided per Section 7.02.07 of this specification and shall be paralleled. The reset button or switch and seal-in relay shall be mounted in the control cabinet and properly labeled.
- 7.04.04** A disconnecting valve shall also be supplied for ease of removing the Sudden Pressure Relay for maintenance.

#### **7.05 Auxiliary Cooling Equipment**

- 7.05.01** Devices for automatic control of single or double-stage cooling equipment shall be provided with the following:

- (1)**
  - (a)** Thermally operated control device with thermal element mounted in a well (as described in ANSI C57.12.00).
  - (b)** The device shall be responsive to winding temperature of the transformer and responsive to the current derived in phase.
  - (c)** The current transformer to furnish this current is to be in addition to those required in Section 6.03.02 herein and shall be shown along with its ratio on the main transformer nameplate.
  - (d)** There shall be an ammeter test jack with a switchblade in the secondary circuit of this current transformer designed to accommodate a Superior test plug, Cat. No. 3614. This test jack shall be located in the main control cabinet for calibration and testing.
  - (e)** The calibration resistor shall be located adjacent to the test jack and properly labeled.
  - (f)** The device shall include a temperature indicator located on the side of the transformer.
  - (g)** Words identifying the function of the indicator shall be on a suitable nameplate, mounted adjacent to the indicator.
  - (h)** The instruction books shall define a procedure for field calibration of the thermometer giving test curves on points.
- (2)** The device shall have three sets of contacts for the following function:
  - (a)** Supply power to first bank of cooling either directly or by control of an auxiliary relay.
  - (b)** Supply power to second bank of cooling either directly or by control of an auxiliary relay
  - (c)** Initiate alarm or actuate a relay with non-grounded contacts provided per Section 7.02.07 of this specification.
- (3)** A switch for automatic and manual control of each bank of cooling equipment is to be located in the control cabinet. Controls to also provide selection of which bank will lead the other with increasing temperature shall be provided on ONAN/ONAF/ONAF and ONAN/OFAF/OFAF rated transformers.

- (4) An electronic loss of voltage relay (or relays) shall be incorporated in the wiring and shall be connected ahead of the switch in Section 7.05.01(3) above and have a thirty second time delay before contact closure to eliminate false indication and shall have non-grounded alarm contacts per Section 7.02.07 herein.
- (6) An overcurrent protective device with manual reset for each bank of cooling equipment in the control cabinet.
- (7) Automatic-trip manual-reset circuit breakers shall be furnished for each bank of cooling equipment and fan control circuit in the control cabinet.

**7.05.02** The following shall apply to cooling fans and fan motors:

- (1) All fan blades shall have OSHA type side and rear guards enclosing them for personal safety. The fans shall also have front guards to prevent birds and other animals from entering the fan housing. Mesh should not exceed ½ inch.
- (2) All fan motors shall have sealed permanently lubricated ball bearings.
- (3) Fans shall be manufactured by Krenz Vent.
- (4) All connections to fan motors shall be watertight.
- (5) Fan motors shall be TENV with automatic reset thermal protectors.
- (6) No fans shall be mounted to the bottom of the radiators. Cooling fans shall not be mounted directly on the radiators but on a removable support structure adequately supported from the main tank.
- (7) All fan motors shall be NEMA MG-1 approved.
- (8) Fan wiring shall be neatly routed around the fan to fan receptacles.

## **7.06 Controls and Wiring**

**7.06.01** All electrical wiring between permanently mounted accessories, current transformer secondaries, bushing voltage devices, etc., and the control cabinet shall be enclosed in a rigid steel conduit securely fastened to the transformer tank in a manner to prevent mechanical damage or vibration.

**7.06.02** All electrical wiring between the control cabinet and the cooling pumps and the fans shall be enclosed in rigid steel conduit, routed on and secured to the tank, up to close proximity points near each motor. All interconnecting raceway between the rigid steel conduit and the motors shall be liquid-tight flexible metal conduit with sunlight resistant jacket. In lieu of using flexible conduit, all motor circuit wiring may be jacketed interlocked armor cable installed between suitable tank-mounted junction boxes and motor terminal boxes.

**7.06.03** All conduit joints and fittings shall be dust tight and watertight.

**7.07** N/A

**7.08 Control Cabinet**

The control cabinet shall be furnished as follows:

**7.08.01** There shall be only one control cabinet to which Purchaser's wiring is to be connected. **Controls cabinet mounted in a location other than Segment I is preferred.**

**7.08.02** The cabinet shall be weatherproof NEMA Type 4X stainless steel with suitable breather and drain kits.

**7.08.03** The door of the cabinet shall swing in the horizontal plane.

**7.08.04** The door shall have a device for keeping it fully open during operation at the cabinet by a workman. Door shall also have 3-point latches for the closed position and shall include provisions for attaching pad locks.

**7.08.05** The door shall have a hinged panel on the inner side that can be lowered to a horizontal position to hold a voltmeter or multimeter while making tests in the cabinet.

**7.08.06** The door shall have a compartment for holding the Instruction Manual and one set of drawings.

**7.08.07** The cabinet shall be at a convenient working height from the base of the transformer.

**7.08.08** A breather and drain shall be provided in base of cabinet.

**7.08.09** The cabinet shall contain the following:

- (1)** Terminals for all Purchaser provided sources such as AC and DC power.
- (2)** Short circuiting terminal blocks for all current transformer leads. See following diagrams for required terminal block layout.
- (3)** All alarm terminals brought to terminal blocks.



- (4) Sudden-pressure relay reset switch.
- (5) Cooling equipment switching devices.
- (6) N/A
- (7) N/A
- (8) A 130 V, LED (equivalent to 125 W incandescent lamp) light with a door switch, and a 120 V duplex receptacle, both protected by a 20A GFI circuit breaker. A second 120 V duplex receptacle not GFCI protected.
- (9) Thermostatically controlled heater for control of humidity. The thermostat shall be set to cut-off when temperature rises above 90 degrees Fahrenheit. Heaters shall be shielded to prevent direct contact by personnel.
- (10) A copper bus bar tapped for #10-32 screws for grounding purposes.
- (11) All other accessories named in this specification which are to be located in the control cabinet.

**Figure 7.2 Transformer Nameplate CT'S And Terminal Block Layout**

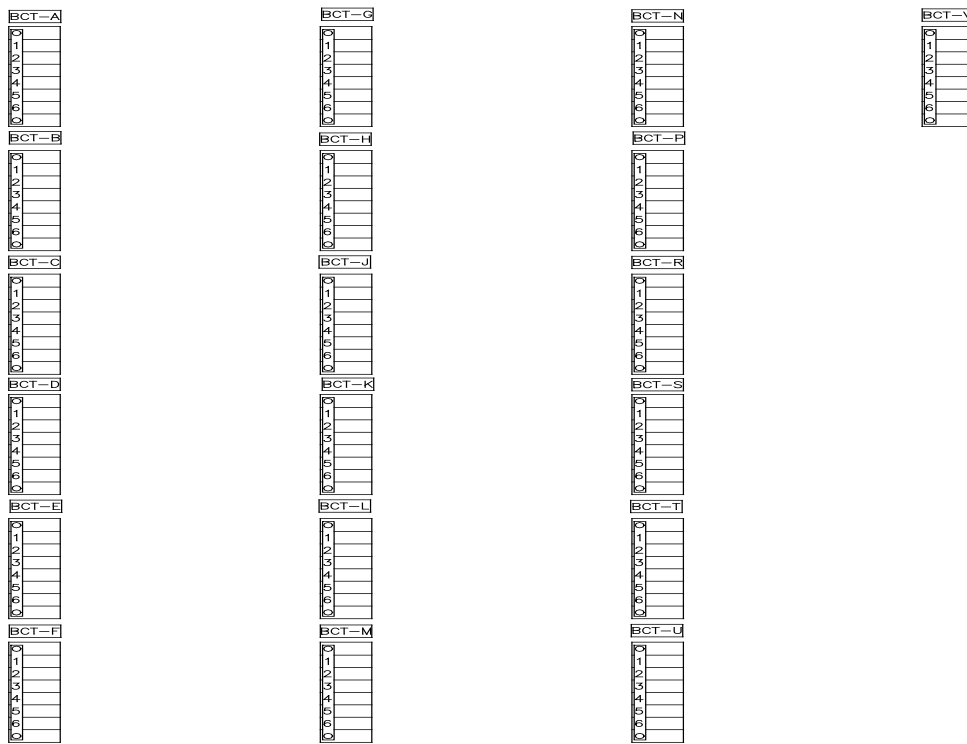

**7.08.10** Annunciators

- (1)** Adjacent to the alarm contact terminal blocks in the main controls cabinet shall be one Ametek annunciator AN-3100D-PM-5-2-INTB-3-27-A-A4-NR-C-DC-TP-SPT-DNP with one normally open and one normally closed contact per alarm input.
- (2)** Wiring shall be provided between the alarm contact terminal blocks and the annunciator point module terminals.
- (3)** The terminals of the annunciators point modules shall be properly and permanently labeled to indicate the alarm function.
- (4)** The Manufacturer shall provide as many annunciators as is necessary to make available to the Purchaser all alarm points provided.
- (6)** Each of the annunciator power supply circuits shall be connected to a 125 VDC power supply terminal block. The annunciator power supply(s) will be supplied by a separate customer connection from the other 125 VDC devices on the transformer.
- (7)** Each of the annunciator's relay module contact terminals shall be terminated on terminal blocks for Purchaser's connections as described in Sections 7.09.01, 7.09.04 and 7.09.06 herein.
- (8)** All wiring specified shall be in accordance with Section 7.21 herein.
- (9)** The purchaser requires, at a minimum, the following alarms to be wired to the terminal blocks and the annunciator(s), if applicable.
  - (a) Transformer sudden pressure
  - (b) Winding temperature (110°C)
  - (c) Winding temperature (100°C)
  - (d) Liquid Temperature (95°C)
  - (e) Liquid Temperature (85°C)
  - (f) Main tank critical low oil level
  - (g) Main tank low oil level
  - (h) Main tank pressure relief
  - (i) Main tank nitrogen pressure high/low
  - (j) Nitrogen System Low Bottle Pressure
  - (k) Cooling system loss of AC power

## **7.09 Monitoring**

### **7.09.01 Transformer Communications and Control**

- (1)** The manufacturer shall provide and install terminal blocks in the main control cabinet to facilitate remote control and indication with the Purchaser's SCADA system.
- (2)** The manufacturer shall provide wiring from the following devices to the terminal blocks:
  - a. Transformer alarm outputs (All alarms described above in Paragraph 7.08.10 (9)).
- (3)** Terminal blocks shall be wired to a normally open contact output of the annunciator panels.
- (4)** Sufficient quantity of terminal blocks are to be provided so that all available annunciator and control points are connected, including 10% spares.

**7.09.02** The bottom of the cabinet shall consist of a bolt-in removable steel plate a minimum of 270 square inches in area and of a gauge similar to that of the main cabinet material. The plate shall be of such dimension that the Purchaser can remove and cut sufficient number and size of conduit holes for the connection of Purchaser's wiring.

**7.09.03** All terminals and equipment shall be legibly and indelibly identified.

**7.09.04** All connecting terminal blocks shall be similar to General Electric type EB-25.

**7.09.05** All current transformer leads shall be individually terminated onto a short-circuiting terminal block equivalent to General Electric type EB-27.

**7.09.06** There shall be no manufacturer connection on the side of the terminal blocks allocated for Purchasers connections. All Purchasers' connections need to be labeled by manufacturer with the correct device label.

**7.09.07** The cabinet shall have a grounding connector for safety grounding. This should be at least ¼ inch by one inch copper ground bus extending the width of the panel.

**7.09.08** All terminal blocks for the Purchaser's connections shall be accessible to the Purchaser's control cable entering the bottom of the cabinet without overlapping other control components in the cabinet.

**7.09.09** All wiring shall be bundled or contained and shall meet the requirements of Section 7.21 of this specification.

**7.09.10** All Controls wiring installed by the Transformer manufacturer shall not be smaller than 14 AWG.

## **7.10 Oil**

Oil for insulating and cooling the transformer shall be provided by the Manufacturer to include oil required for topping off after installation at the final destination for all transformers according to the following.

**7.10.01 General:**

- (1) The oil furnished under this specification shall be **Type II** Mineral Oil as described in ASTM D3487 (Latest Revision).
- (2) The oil furnished under this specification shall meet the characteristics stated in the aforementioned industry standards or the references therein.
- (3) The requirements specifically stated within this specification shall govern should there be any conflicts with the above standards or the references therein.
- (4) The oil shall be deemed not to cause copper oxidation within the windings.
- (5) The oil shall also conform to any additional or more stringent requirements imposed by the transformer manufacturer in order that the oil is completely compatible with the transformer insulation system.

**7.10.02 Characteristics:**

- (1) The physical properties of the insulating oil as received shall meet the following requirements:

**Table 7.3 Insulating Oil Characteristics**

Characteristic	Value	Related Standard
Aniline point	63-78°C	ASTM D611
Color	0.5, max	ASTM D1500
Chlorides and Sulfates	None	ASTM D878
Corrosive Sulfur	Noncorrosive	ASTM D1275
Dielectric Breakdown Voltage @ 0.10 in @ 1 mm @ 2 mm	30 kV min 28 kV min 56 kV min	ASTM D877 ASTM D1816 ASTM D1816
Dielectric Breakdown Voltage, Impulse Conditions	145 kV, minimum	ASTM D3300
Flash Point	145°C, min	ASTM D92
Furanic Compounds	25 µg/L max	ASTM D5837
Gassing Tendency uL/min	+30 max	ASTM D2300
Interfacial Tension	40 dyne/cm @ 25°C, minimum	ASTM D971
Moisture Content	25 ppm max	ASTM D1533
Neutralization Number	0.015 mg KOH/g, max	ASTM D974
Oxidation Inhibitor (% by weight)	0.3%	ASTM D2668
Oxidation Stability (rotating bomb test)	195 minutes, minimum	ASTM D2112
Polychlorinated Biphenyl	Not detectable	ASTM D4059
Pour Point	-40°C max	ASTM D97
Power Factor	0.05 max @ 25 °C 0.3 max @ 100°C	ASTM D924
Saturation Concentration	60 ppm H <sub>2</sub> O @ 25°C, max	
Specific Gravity	0.91 @ 15°C/15°C, max	ASTM D1298
Viscosity (SSU/cSt)	36/3 @ 100°C, max 62/11 @ 40°C, max 350/76 @ 0°C, max	ASTM D88/D445
Visual Examination	Clear and Bright	ASTM D1524
Weight	7.5 lb/gal	

### **7.10.03 Inspections-Tests:**

#### **7.10.03.1 Manufacturer**

The Manufacturer shall perform a chemical analysis and submit a certified chemist's report to Purchaser on the contents of each refinery storage tank used for filling each truck to show that the requirements of the characteristics chart above have been met or exceeded.

#### **7.10.03.2 Transport truck**

Oil shipments shall be shipped in transport trucks under the following requirements unless otherwise approved by the Purchaser.

- (a)** The tanks, including the lower valves and piping, shall be thoroughly cleaned, dried, and flushed with oil before filling for shipment.
- (b)** The oil shall not be placed in the tanks if there is any moisture contamination in the tank, valves, and/or piping.
- (c)** A dry nitrogen (10 ppm H<sub>2</sub>O max) positive pressure blanket shall be placed above the oil in the tanks.
- (d)** Oil shall be shipped in dedicated tankers capable of pressuring off oil with dry air. Only oil shipped in this manner will be accepted. Shipment of oil in barrels is not acceptable.

### **7.11 Oil Preservation Systems**

**7.11.01** The Manufacturer shall supply an inert gas pressure system in accordance with ANSI C57.12.10, C57.12.30, and C57.12.80. Conservator or expansion tank systems are allowable on EHV transformers only.

**7.11.02** The inert gas pressure system is one in which the interior of the transformer (by means of a positive pressure of inert gas maintained from a separate inert gas source and reducing valve system) is sealed from the atmosphere throughout a top-oil temperature range of 100 degrees Centigrade, and the internal pressure does not exceed 8 psi gauge. The transformer shall be furnished complete with reducing valves, gauges and tanks of nitrogen necessary to purge the gas space and place the transformer in service.

- (1)** The inert gas shall be dry nitrogen with less than 0.5 percent by volume of impurities and less than 0.03 percent by weight of moisture.
- (2)** The nitrogen shall be supplied in 200 cubic foot cylinders equipped with connection No. 580 of ANSI B57.1, a minimum working pressure of 2,015 psi, and the appropriate transfer of ownership documentation for refilling. Cylinders shall conform to regulations of the United States Department of Transportation (DOT), Texas Department of Transportation (TxDOT), and Louisiana Department of Transportation and Development (LaDTAD), and appropriately marked as such.

- (3) The nitrogen bottle shall be in a weatherproof cabinet at base level.
- (4) The gauges shall monitor and regulate the gas pressure of the transformer tank and monitor the gas pressure of the nitrogen bottle.
- (5) All transformers shall have a provision for sampling tank gas. This provision shall consist of a valve and fitting designed to accommodate one-quarter inch I.D. "Tygon"-type tubing. This shall be located inside the nitrogen bottle cabinet. The gas sample location on the transformer tank shall be valved and shall be located at an opposite end of the tank from the gas filling location. All rigid gas tubing shall be Stainless Steel.
- (6) A non-grounded alarm contact shall be provided per Section 7.02.07 herein for detection of low gas pressure.
- (7) A gas detector relay similar to GE Type GEK-4817 shall be provided on transformers that have a conservator or expansion tank system. The relay shall have a non-grounded alarm contact per Section 7.02.07 herein.

## **7.12 Pressure Relief Valve**

A pressure relief device shall be located on the cover. Electric alarm contacts and mechanical target operation of the device are both required.

- 7.12.01** The non-grounded electrical alarm contacts shall be provided according to Section 7.02.07 of this specification. The contact leads shall be terminated in the control cabinet.
- 7.12.02** The mechanical target shall be capable of being viewed from ground level.
- 7.12.03** The target shall also be capable of being reset by a hot stick while the transformer is energized.
- 7.12.04** Pressure relief device shall be manufactured by Qualitrol and sited in accordance with manufacturer's recommendations for the transformer ratings.

## **7.13 Tanks**

### **7.13.01 Design**

- (1) The main transformer tank and any attached compartment that is subjected to operating pressures shall be designed to withstand, without permanent deformation, positive internal pressures of at least 10 psig and negative internal pressures equivalent to a complete vacuum. pressure 25 percent greater than the maximum operating pressures resulting from the system of oil preservation used.
- (2) The maximum operating pressures (above and below standard atmospheric pressure) that the transformer tank is designed to withstand shall be indicated on the nameplate.

- (3) Tanks shall be designed for vacuum filling (essentially full vacuum) in the field. Auxiliary compartments, when not designed for vacuum filling, shall be so designated and valves shall be provided to isolate them from the main tank. Specific instructions concerning vacuum procedures shall be defined in the instruction manual.
- (4) Main cover shall be of welded construction with a one and one-half inch coupling and tapered plug. A 1-1/2" NPT coupling shall be welded at each corner on the top cover so Purchaser can install a temporary rope/pipe safety fence when doing maintenance on top of the transformer.

**Note:** All plugs in this specification shall have external square heads. No allen head fittings are allowed. Also, cast type plugs are not acceptable.

- (5) One or more manholes shall be provided in the cover:
  - (a) Removable bolted covers shall be provided.
  - (b) The manhole covers should be flat with a minimum diameter of 20 inches.
  - (c) Covers weighing more than 45 pounds shall be hinged and removable.
  - (d) All covers shall have handles.
- (6) All joints for tank and manhole covers, bushings, and other bolted covers shall be gasketed. These joints shall be designed so gaskets will not be exposed to the weather, and shall be provided with mechanical stops to prevent crushing. Gaskets shall be recessed and machine grooved. One set of spare gaskets shall be provided with each unit.
- (7) All tank seams shall be double welded (inside and outside) shall be oil and gas tight and shall be a minimum of six (6) inches from the corners. Corner welds are not acceptable.
- (8) Use of Plastic tie-wraps to secure or support wires, tubes or components at Transformer exterior is **not acceptable**.
- (9) Any tubing more than 6" in length shall be adequately supported at regular intervals. This criteria also applies to Conduits, gauge probes, capillaries and Nitrogen tubing.
- (10) **All external hardware shall be Stainless Steel.**
- (11) Seal welding shall be utilized to minimize accumulation of moisture within cavities or pockets.
- (12) Cover shall be domed to shed water and welded to the tank. Measures must be taken to prevent the entrance of weld spatter into the tank during welding of the transformer cover. Transformer cover shall have nonskid surface.



- (13) A device suitable for mounting a safety device in the approximate center of the tank cover and capable supporting hardware including harnesses utilizing gravity brakes shall be provided.
- (14) All gasketed openings shall be designed with means provided for controlled compression of the gasket with recessed gaskets or metal-to-metal stops, and re-usable gaskets of oil resistant material. All gasketed joints on top of the transformer shall utilize flanges, which are raised at least 3/4 inch above the cover surface.
- (15) As far as practicable, gaskets below the oil level shall be eliminated.
- (16) All external tank supports or stiffeners shall be box beam construction and continuously welded.
- (17) The transformer base shall be structurally capable of withstanding sliding or rolling in any direction parallel to the center lines with the transformer fully assembled and full of oil.
- (18) Where the skid plate base construction or fabricated base construction provides for ventilation, openings shall be provided to minimize condensation accumulation within the base itself. For fabricated base designs, the bottom of the tank base and the inside surface of the base that is directly or indirectly exposed to external environmental conditions shall be coated with a heavy corrosion-resistant compound which will not be affected by insulating oil or temperature.
- (19) Provisions shall be made for anchoring the transformer to the foundation by anchor bolts or by welding the base to steel embedded in the foundation. Anchorage design shall meet the requirements of the American Society of Civil Engineers (ASCE) Substation Structure Design Guide.

**7.13.02 N/A**

**7.13.03 N/A**

**7.13.04 Grounding**

**(1) Ground Halo**

Grounding for the transformer should be accomplished through the use of a grounding halo. Grounding halo shown in Figure 7.4. shall consist of 2" x 1/4" solid copper busbar. Grounding halo consisting of looped conductor is not acceptable. A grounding halo as shown on the typical drawing should be installed on both back and front of the transformer. Additionally, two copper busbars shall be run from front to back of transformer to connect both front and back halos. They shall be run on the side wall.

**(2) Tank Ground Pads**

A NEMA 2-hole or 6-hole steel based copper-faced pad shall be welded to the tank in each of the following locations (see Typical Drawing on next page):

- (a) Adjacent to the Ho bushing on top of tank (one 2-hole pad).
- (b) Six inches up from the bottom on left and right corners, on both high voltage and low voltage sides of the transformer (four 6-hole Type-N pads).
- (c) Approximately one-third of the vertical distance from the pads mounted on the lower left and lower right corners of the transformer to the top of the transformer, on both high voltage and low voltage sides of the transformer (four 2-hole pads).
- (d) Approximately two-thirds of the vertical distance from the pads mounted on the lower left and lower right corners of the transformer to the top of the transformer, on both high voltage and low voltage sides of the transformer (four 2-hole pads).
- (e) Thread protection for these ground pads during shipment shall consist of a flanged cup of a non-corrosive material suitable for press fitting into threaded openings.

**(3) Neutral Bushing Grounding**

- (a) The Ho bushing shall have a stud to NEMA 4-hole pad copper connector.
- (b) A ground strap shall be furnished from the Ho terminal to the adjacent tank ground pad.
- (c) A suitably sized copper bar shall be installed from the tank ground pad of 7.13.04 (2)(a) to the pad of 7.13.04(2)(b). The bus bar shall have suitable supports to tank.

- (4) Surge Arrester Grounding** The surge arresters furnished on the transformer shall be grounded to all four tank ground pads listed in 7.13.04 (2)(b) or (c) above. These grounds shall be copper bars with suitable supports on tank for all bars.

Figure 7.4 Transformer Tank Grounding Pads  
(Typical)

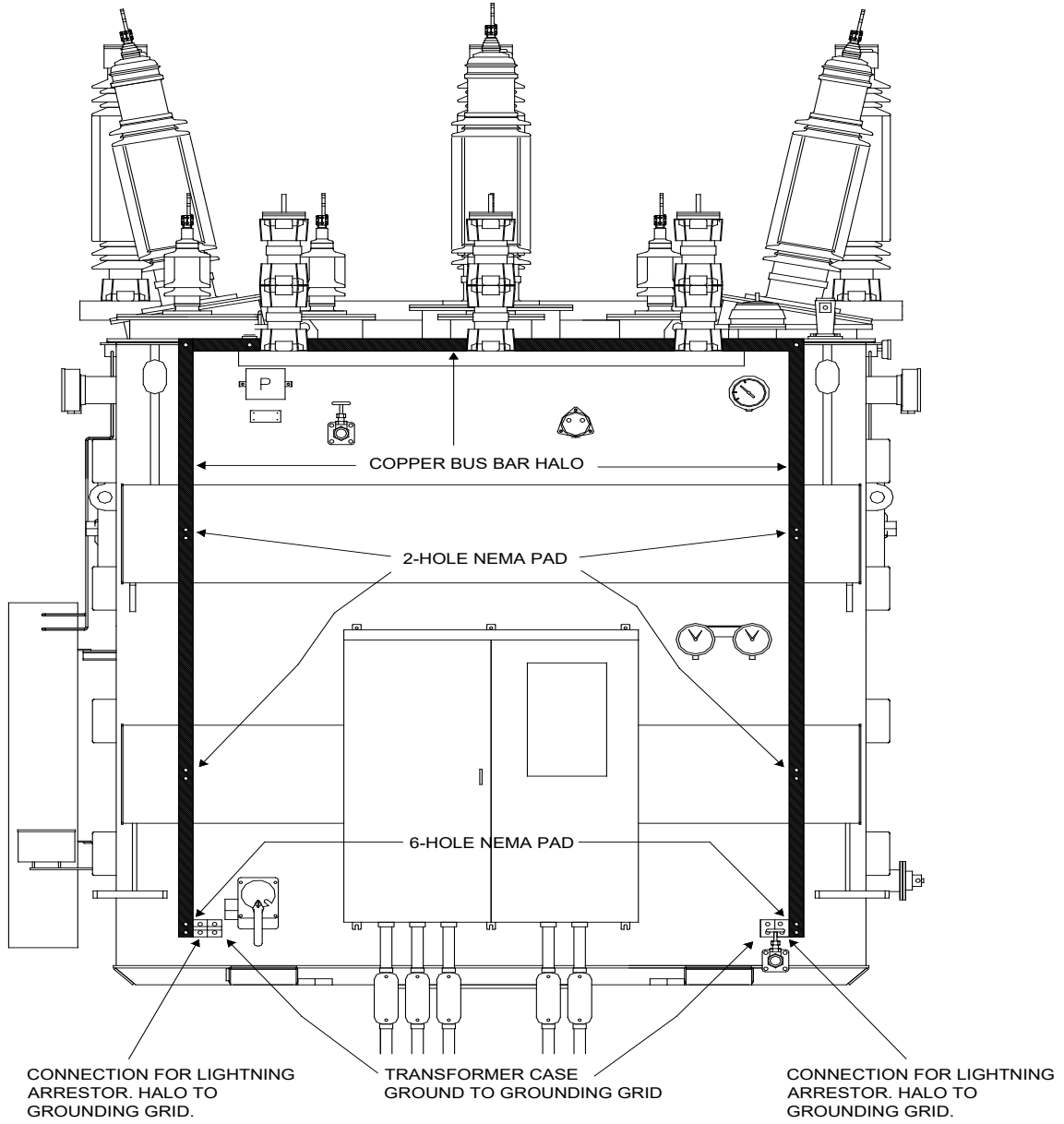

**(5) Core Ground**

- (a)** The location of core ground(s) shall be indicated on the outline drawing.
  - (b)** Transformers shall have the core ground(s) terminate through the tank wall by means of a suitably rated bushing for proper core insulation. Each core shall have a separate ground and bushing (main, series, preventative auto, etc.).
  - (c)** The bushing(s) shall be housed in a weather resistant protective metal housing.
  - (d)** The ground bushing terminal(s) shall be connected by cable or strap to an adjacent ground pad welded to the transformer tank wall. The cable or strap shall be easily removable for core ground resistance testing. These grounding pads shall have a continuous electrical connection to the transformer grounding pads listed in 7.13.04 (2)(b) through the ground halo with adequate supports to the tank.
- (6)** The Purchaser shall connect tank ground pads to substation ground grid to complete adequate transformer grounding protection. Two holes shall be maintained on the tank ground pads of 7.13.04 (2)(b) or (c) for Purchaser's use.

**7.13.05 Drain and Filter Valves**

- (1)** A combination drain and lower filter valve of the globe type shall be provided.
- (2)** This valve shall provide for complete drainage of the liquid and for outlet to oil filtering means.
- (3)** The size of the drain valve should be 2-inches and it should have 2-inch NPT threads with a pipe plug in the open end.
- (4)** The drain valve shall have a built-in 3/8-inch sampling device that shall be located in the side of the valve between the main valve seat and the pipe plug.
- (5)** The sampling device shall be supplied with a 5/16-inch, 32 threads per inch, male connector equipped with a cap.
- (6)** An upper filter valve of the globe type, located in the same segment of the drain valve, should be located below the 25 degrees Centigrade liquid level, suitable for the return of filtered oil.
- (7)** The size of the upper filter valve shall be 2-inch and shall have 2-inch NPT threads with a pipe plug in the open end.

#### **7.13.06 Lifting Facilities**

- (1)** Means for lifting the complete transformer by overhead crane shall be provided. No accessories shall be installed that would interfere with rigging used to lift transformer.
- (2)** The bearing surfaces of the lifting means shall be free from sharp edges. Facilities for guying the transformer during transport shall be provided.
- (3)** Lifting means shall be provided for removing the lid and untanking the transformer.

#### **7.13.07 Moving Facilities**

- (1)** The base shall permit rolling or sliding in the directions of both centerlines of the transformer and attachment holes in base structure shall be provided for pulling the transformer in these directions.

The base shall be so designed that the center of gravity of the transformer, as normally prepared for shipment, shall not fall outside the base support members for a tilt of base of 15 degrees from the horizontal, with or without oil in the transformer.

- (2)** The transformer center of gravity for (a) shipment and (b) fully assembled transformer (including oil) shall be permanently marked and labeled on all four tank walls.

#### **7.13.08 Jacking Facilities**

- (1)** Jacking facilities shall be located near the corners of the base.
- (2)** The jack ports or lugs shall be so designed that the jack can be inserted.
- (3)** The transformer base and tank shall be constructed to permit jacking and lifting without any permanent structural deformation when the transformer is assembled and filled with oil.
- (4)** Dimensions and clearances for jacking provisions shall be as shown below in Figure 7.5.

Figure 7.5

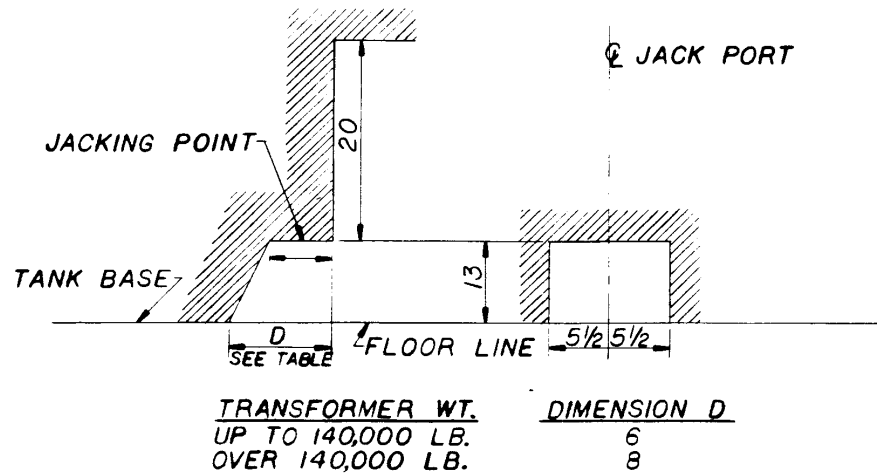

**NOTES:** ALL DIMENSIONS ARE IN INCHES.  
 WHEN MANUFACTURER'S STANDARD DESIGNS REQUIRE, ANY  
 DIMENSION MAY BE IN EXCESS OF THOSE SHOWN.

**7.13.09 Paint Requirements**

- (1) All metal surfaces shall be cleaned before applying primer.
- (2) Two coats of primer shall be applied to all exposed metal surfaces (except to the transformer top plate where insulating paint shall be applied per paragraph (6) below) using application methods recommended by paint Manufacturer.
- (3) A minimum of two top coats shall be applied to all exterior primed surfaces using application methods recommended by paint Manufacturer.
- (4) The top coat shall be ANSI No. 70, Sky Gray, Munsell #5.OBC7.0/0.04.
- (5) The topcoat thickness shall be at least 3 mils at all points.
- (6) The transformer tank top surface shall be covered with protective silicon coating, room temperature vulcanizing (RTV) insulation of silicon rubber technology, Product No. 587, as manufactured by MIDSUN Group, Southington, CT, (Phone 1-800-MIDSUN), or Purchaser approved equal. The coating shall be applied per manufacturer's instructions and shall have the following characteristics:

- (a) Dielectric strength (ASTM D149), 375 volts/mil.
  - (b) Volume Resistivity (ASTM D257), ohm-cm  $3.0 \times 10^{15}$
  - (c) Dissipation Factor (ASTM D257), 100 Hz. – 100 kHz: .01
  - (d) Dielectric constant (ASTM D150), 100 Hz – 100 kHz: 4.0
  - (e) Shrink Factor: Nil
  - (f) Coating is required to minimize risk of flashover caused by snakes, varmints, etc.
  - (g) Silicon coating shall be a minimum thickness of 30 mils at all points including all junction boxes, tank lid, and other extrusions.
  - (h) The transformer tank top after application of the RTV coating shall be skid resistant and its color shall match the rest of the tank.
  - (i) All top surfaces of the tank shall be coated, including tank, hatch covers, CT and core junction boxes, bushing flanges and any other metal extension or attachment which protrudes from the tank top surface.
- (7) The interior of the tank shall be painted white with a paint that is not affected by the transformer oil.
  - (8) A suitable warning label shall be affixed to the hatch covers listing appropriate procedures and precautions to be followed when removing the covers. The warning labels shall be applied to the covers after application of the protective silicon coating described in Paragraph (6).
  - (9) All surfaces of ferrous metalwork for each transformer shall be cleaned and prepared in accordance with the manufactures standard procedures.
  - (10) The transformer shall be painted in accordance with the manufactures standard procedures.
  - (11) Two 1-pint Aerosol spray touch-up paint cans of each color shall be supplied with the transformer.

#### **7.13.10 Radiators**

- (1) The transformers shall be equipped with fully galvanized removable radiators or coolers for heat radiation. All radiators on the transformer must be interchangeable.
- (2) Radiator panel steel thickness shall be a minimum of 18 gauge.
- (3) Radiators shall be attached to the tanks by means of bolted and gasketed flanges.

- (4) A drain plug shall be provided in each lower radiator header or radiator bank. A vent plug shall be provided on the upper radiator header to prevent air being trapped.
- (5) Clearances shall be large enough to permit painting and maintenance of tank, tubes, and radiators.
- (6) Radiators and coolers shall be designed to withstand the same maximum and minimum pressures required of the main tank. Radiators shall be capable of withstanding full vacuum.
- (7) Removable radiators and coolers shall be fastened to transformer case with bolted flange connectors. Bolted flange connectors must not bear any weight of the Radiator assembly.
- (8) Butterfly valves or other suitable devices shall be provided to permit the ready installation and removal of radiators and drainage of oil from radiators without drawing oil from transformer tank. Verification of valve shutoff capability shall be documented to the Purchaser in final test reports that are submitted.
- (9) There shall be no external valve levers or stops constructed of plastic or aluminum material.
- (10) Radiators and coolers shall be equipped with lifting eyes, and so designed that they may be handled without the addition of special bracing.
- (11) The top and bottom of each radiator assembly shall have a vent and drain coupling and plug. The coupling is to be American Pipe Standard with 3/4 inch tapered plug.
- (12) Radiators shall not be placed on the low voltage bushing side of the transformer.

#### **7.14 De-energized Tap Changer**

- 7.14.01** High Voltage windings shall have a tap changer for de-energized operation with an operating handle located on the side of the tank at a height convenient for operation from the base level. (No more than 6 feet above ground level.)
- 7.14.02** Ratings for the de-energized tap changer shall meet the requirements of Section 6.00 of this specification.
- 7.14.03** The tap changer handle should have provisions for padlocking, consisting of a 3/8-inch minimum diameter hole, and shall provide visible indication of the tap position without unlocking or requiring use of tools to remove DETC cover. For a given winding, the number 1 or the letter A shall be assigned to tap having the greatest number of effective turns. All tap changer and series-parallel switch handle shall be clearly labeled near their mounting on the main tank with their own nameplate. This nameplate shall also have information on which winding they cater to, all tap and switch positions with corresponding voltages.



- 7.14.04** If more than one de-energized mechanism is required, such as a series-multiple, the handle shall be gang operated.
- 7.14.05** Contacts shall be self-cleaning and shall be mechanically and thermally adequate to withstand fault currents up to 25 times full load current for 2 seconds.
- 7.14.06** The tap changer shall be located so as to provide for maintenance and inspection without untanking.

**7.15** N/A

**7.16 Current Transformers**

- 7.16.01** Multi-ratio bushing current transformers shall be provided with the ratio and quantity as specified in Section 6.03 of this specification. Fixed or dual ratio metering current transformers shall be provided with the ratio and quantity as specified in Section 6.03 of this specification.
- 7.16.02** All Bushing current transformers shall conform to ANSI C57.13.
- 7.16.03** Accuracy classification of bushing relaying current transformers shall be C800. Accuracy classification of bushing metering class current transformers shall be 0.3B1.8.
- 7.16.04** All secondary leads of current transformers shall be brought to a common outlet box near the cover and then to the weatherproof control cabinet where each lead shall be terminated on a short-circuiting type terminal block per Section 7.09.05 of this specification. There shall be one terminal block for each multi-ratio current transformer.

**7.17 Surge Arresters**

- 7.17.01** Transformer shall be supplied with mounting hardware for surge arresters. The Supplier shall verify the arresters selected provide protection of the insulation system per IEEE C62.22-1997 "IEEE Guide for the Application of Metal-Oxide Surge Arresters for Alternating-Current Systems".
- 7.17.02** Surge arresters shall be polymer construction, Hubbell EVP Type or approved equivalent, provided with the rating as specified in Section 6.05 of this specification.
- 7.17.03** The mounting of the arresters shall be adjacent and convenient to the bushing to which it connects.
- 7.17.04** The top terminal of the surge arrester shall be on same level as the top terminal of its partner bushing.
- 7.17.05** The surge arresters shall be grounded per Section 7.13.04 of this specification.
- 7.17.06** The grounding of surge arresters shall follow the methods recommended in IEEE Standard No. 80 except as stated herein.

**7.17.07** All surge arresters shall be provided with a NEMA 4" x 4", four-hole pad: aluminum or cadmium, silver or tin-plated on top for the Purchaser to connect to.

**7.17.08 Applicable Standards:**

**Industry Standards**

American National Standards Institute (ANSI) C62.11 - Standard for Metal-Oxide Surge Arresters for Alternating-Current Power Circuits.

**General:**

Arresters provided shall in all respects meet the dimensional and performance requirements hereinafter stated and as stated in the above standards or the references therein. The requirements specifically stated herein shall govern should there be any conflict with the above standards or references therein.

Items shall be manufactured in a good workmanlike manner using quality material free from any defects.

**7.17.09 Classification Or Rating:** (See 6.05.01)

**7.17.10 Construction**

Arrester shall be metal oxide type.  
Polymer housing to be ANSI #70 (Light Gray) color.  
Terminals

- (1) The top terminal shall have a four-hole NEMA pad.
- (2) The bottom terminal shall have an "L" bracket for attaching an Anderson Electric TLS-42 type bronze eyebolt connector furnished by Purchaser for grounding.

**7.17.11 Inspections-Tests:**

**Manufacturer**

Manufacturer shall perform production and final inspections to assure that the items have been manufactured in accordance with the requirements specified herein.

Design tests shall be made on arrester units as described in ANSI C62.11.

Routine production tests shall include the following:

- (a) Radio influence voltage
- (b) Grading current
- (c) Seal integrity

**7.18 Tertiary Winding – N/A**

**7.19 Auxiliary Control Power**

- 7.19.01** The Purchaser shall provide the necessary station service power for operating the auxiliary cooling equipment.
- 7.19.02** The voltages available shall be 240/120 V, AC, single-phase, 3-wire and 125 VDC.
- 7.19.03** The Manufacturer shall state single-phase kVA requirements in the Bid Proposal form found in the Appendix of this specification.

**7.20 Nameplate**

- 7.20.01** The transformer shall have a stainless steel nameplate designed per ANSI C57.12.00, Section 5.12 except as stated herein. The nameplate shall be permanently attached to the transformer on the outside of the control cabinet door with non-corrosive hardware at a height and location for easy reading from the ground.
- 7.20.02** In addition to the standard nameplate data, the following special design features data shall be included on the nameplate if applicable to the transformer(s) being furnished:
  - (1)** Extra over-excitation capability in excess of that provided by NEMA Standards.
  - (2)** Special short circuit requirements.
  - (3)** Temperature rise design and guarantee based on an altitude above 3300 feet.
  - (4)** Detailed tap changer information including at a minimum, tap position voltages and maximum line currents.

**7.21 Auxiliary Wiring**

- 7.21.01** All wiring shall be 600 volt, flame resistant, moisture resistant, heat resistant, oil resistant, 90 degrees Centigrade rated insulation over copper conductors.
  - (1)** No. 12 AWG minimum for power, No. 14 AWG minimum for controls and No. 10 AWG minimum for CT'S.
- 7.21.02** Each stranded conductor shall have ring tongue compression type terminals. Solid conductors shall have cup washers for screw post connections.
- 7.21.03** All conductor terminations shall be designed to fit on General Electric type EB terminal blocks.

- 7.21.04** Each end of a conductor shall be permanently labeled with machine printed heat-shrink vinyl markers.
- 7.21.05** All wiring shall be bundled or contained.
- 7.21.06** All auxiliary wiring external to the transformer shall be in conduit with weatherproof fittings and shall not be installed across the cover or within structural bracing.
- 7.21.07** All conduits shall be rigid metal conduit, except where short flexible lengths are required for isolating vibration.

**7.22** N/A

**7.23 Transformer Windings**

- 7.23.01** All transformer windings shall be copper for all MVA ratings of transformers listed.
- 7.23.02** Winding conductors shall be free from harmful scale, burrs and splinters. Conductors shall be designed so that eddy current losses are kept as low as practicable, and so that the required mechanical strength is ensured. All conductor joints shall be brazed or welded.
- 7.23.03** Conductors shall be uniformly insulated with high dielectric strength insulating materials capable of withstanding, without degradation, the maximum hottest-spot temperatures possible with operation under the most severe combinations of load; ambient temperature and voltage conditions specified.
- 7.23.04** Conductor in leads to bushings shall be copper.
- 7.23.05** All leads from the windings to the terminal board, tap changer, switches and bushing shall be rigidly supported with adequate top and bottom clamping to prevent damage from vibration or normal installation flexing. Leads must not be supported by strings and must not have their weight carried by suspended strings. Short runs (Maximum of 6" from Support to lead) of strings may only be used when required to maintain electrical and mechanical clearances from internal components but they must not carry any weight of the leads.
- 7.23.06** Windings shall be circular wound concentric type using a continuous disc or helical wound winding design including Reactor and Series transformer windings, if present. Regulating windings shall be fully distributed type, where each turn traverses the complete electrical height of the winding.
- 7.23.07** Bolted connections are acceptable only to form lead to bushing connections. All other connections must be welded, brazed or made with compression connectors and adequately insulated.

**7.23.08** The edges of all non-circular conductors shall be rounded to help prevent the rubbing or cutting of insulation as a result of mechanical oscillations caused by normal service, energization, or through fault currents.

**7.23.09** Windings shall be vacuum processed (vapor phase) and oil impregnated prior to final sizing.

## **7.24 Transformer Core**

**7.24.01** The core shall be of circular (cruciform) configuration with multiple step-lapped fully mitered joints and shall be tightly clamped, the coils shall be securely fixed to the core, and the core and coils shall be rigidly fixed in the tank to prevent movement under short circuit stresses and during handling in shipment. The structure shall be securely grounded at a single point to prevent electrostatic potentials.

**7.24.02** The core laminations shall be of high-grade, grain-oriented, non-aging electrical silicon steel of low hysteresis loss and high permeability. The core legs shall be securely held by an acceptable means.

**7.24.03** The core laminations shall be free of all burrs and sharp projections. Each sheet shall be resistant to the action of hot oil.

**7.24.04** The core shall be constructed of the high quality, non-aging, cold-rolled, grain-oriented, stress-free, silicon-steel laminations having high permeability and low hysteresis loss. The steel shall be properly annealed and have smooth surfaces at the edges. Each sheet shall have an insulated surface which is impervious to hot transformer oil. The core shall be rigidly clamped and blocked to prevent deteriorating vibrations, interference with oil circulation, short circuits, objectionable noise levels, and shipment distortions. Any internal blocking or bracing used which is to be removed from the transformer at its destination shall be painted a bright color, such as red or yellow.

**7.24.05** The transformer, including all core and coil assemblies, shall be power class, round core/circular coil design and construction. High voltage and low voltage windings for the main core/coil assembly shall be either disk or helical construction, layer/barrel windings are not acceptable. All windings shall be copper conductor and either rectangular magnet wire or continuous transposed cable. All transformer windings shall be designed and wound with maximum short circuit strength as a primary design criterion. All windings shall be furnished with insulation that will permit continuous operation at a winding rise of 65°C above ambient and a hotspot rise of 80°C without affecting normal life expectancy of insulation. Winding leads shall be readily accessible from a manhole in the tank cover.

- 7.24.06** The core design shall optimize core weight, core loss, flux density and noise.
- 7.24.07** Each portion of the core shall be grounded at a single point. Core grounding shall be brought out on the cover through a bushing and grounded externally to facilitate testing.
- 7.24.08** Lifting provisions to facilitate handling the core and coil assembly shall be provided.
- 7.24.09** Insulation on all conductors used in the coil winding process shall be cellulose insulating paper. It shall be wound onto the conductor employing a spinning process. The paper insulation shall be applied in single or multiple strands such that a minimum of 30% of the paper surfaces are overlapped to provide for a continuous insulating surface. Sufficient tension shall be maintained on the paper strands so as to prevent loose wraps. If clamping rings are utilized in the transformer design, full circumference rings shall be used. Core and coils shall be dried using a “vapor phase” system prior to filling.
- 7.24.10** Factory Drying: The transformer shall be factory processed during fabrication to remove all absorbed and surface moisture from each core and coil assembly and from each completed moisture-degradable shipping assembly. Coils shall be dried before assembly on core. All bolts and nuts in the core winding assembly must be re-torqued after the drying process.

## **7.25 Seismic Qualification**

- 7.25.01** Seismic requirements for this equipment shall be qualified to the low performance level as defined in the later revision of IEEE Standard 693.
- 7.25.02** Specifically, anchorage shall be capable of withstanding the resultant loadings applied in the horizontal and vertical planes as described in IEEE Standard 693.
- 7.25.03** Additionally, the load path as defined in IEEE Standard 693 will be established so that it does not incorporate materials that have unrestrained movement or rotational degrees of freedom and/or non-elastic deformation, with collapse members designed to cascade.

## **8.00 DRAWINGS AND INSTRUCTION MANUALS:**

### **8.01 General**

- 8.01.01** The drawings and instruction manuals shall be furnished as specified herein. All drawings and manuals shall be in English. Drawings shall also contain original Manufacturer's part number information for components such as Part number and other necessary information.
- 8.01.02** The list of drawings and instruction manuals shall be as specified below.
- 8.01.03** The drawings and instruction manuals collectively shall contain sufficient information to enable the Purchaser to adequately receive, assemble, install, operate, overhaul, and order renewal parts for all equipment ordered. Drawings and instruction manuals will be provided for all auxiliary equipment.
- 8.01.04** When the drawings and instruction manuals for a particular order covers a range of similar equipment, the information applicable to that order must be specified.
- 8.01.05** The following information must be provided on every drawing and instruction book:
- (1)** Purchaser's purchase order number and item number.
  - (2)** Vendor's name and order number if applicable.
  - (3)** Manufacturer's shop order number and/or sales order number.
  - (4)** Manufacturer's drawing number and title including revision number.
  - (5)** Identification as an approval or final (certified) drawing.
  - (6)** Date of transmittal.
  - (7)** Date deadline of receipt of "Approved as Noted" drawings by Manufacturer from Purchaser to maintain construction schedule.

### **8.02 Approval Drawings**

- 8.02.01** The drawings listed below shall be submitted for approval. Drawings which are not approved and/or request a revision by the purchaser shall be re-submitted to the Purchaser for final approval. All drawings in the six categories listed below must be submitted on one transmittal. Partial submittals at different dates will not be accepted by the Purchaser.

1. Outline - showing location of all external parts and accessories
2. Nameplate
3. Wiring diagrams
4. Control panel layout

5. Bushing and arrester outline drawings
6. Ground bar detail drawing per section 7.10.02
7. Gauges, Fan, Dehydrating breather, Pressure Relief Device and Sudden Pressure Relay details
8. Nitrogen cabinet details and layout
9. Details of how dis-assembled parts would be shipped including make-up oil, if any

**8.02.02** Details of De-energized tap changer and switch.

**8.02.03** The Manufacturer shall furnish electronic copies of all drawings applicable to this order for approval by the Purchaser unless drawing approval is waived in writing by the Purchaser. When drawing approval is waived, certified drawings shall be substituted. Certified drawings shall be in both dwg and pdf format.

**8.02.04** Manufacturer shall submit approval drawings as soon as practical, but in no case later than twenty-four (24) weeks after receipt of Purchaser's purchase order.

**8.02.05** The Purchaser will return one set of drawings marked:

**"APPROVED EXCEPT AS NOTED"**

Note: Purchaser may return a letter or e-mail indicating no changes or comments in lieu of returning drawings if there are no comments.

This action by Purchaser does not relieve Manufacturer of responsibility of:

- (1) Strict adherence to the specifications except where deviation is fully described in writing by Purchaser and
- (2) For corrections of engineering, draftsmanship, design, workmanship, materials, and all other matters and liabilities hereunder, such as product liability and delivery schedule.

**8.02.06** Approval drawings shall be supplied in AutoCAD 2010 format. All drawing files shall be submitted on a CD-ROM labeled with all transmittal information. The CD-ROMs shall be shipped in a protective shipping container, clearly labeled with the purchase order number and item number. Drawings may be E-mailed to the Purchaser if desired.

**8.03 Certified For Construction Drawings**

After Manufacturer receives approval drawings from Purchaser, any changes shall be made per Purchaser's request and any other Manufacturer's changes at that time shall be incorporated into the drawings. These revised drawings shall be sent to Purchaser as noted above (the sets of printed drawings and AutoCAD CD-ROMs). These drawings shall be sent as immediate as practicable (ASAP) to Purchaser, but in no case later than six (6) weeks after receipt of approval drawings from Purchaser. This is to allow Purchaser to proceed with design. These drawings shall be noted as "Certified For Construction." **The drawings shall indicate clearly any and all changes to each drawing since the approval drawings were accepted.**



#### **8.04 Final "As-Built" Drawings**

Final "As-Built" drawings shall be issued to the Purchaser as final drawings. Also, one set of drawings shall be located in the control cabinet.

- (1) Outline
- (2) Nameplate
- (3) Wiring diagrams
- (4) Shipping outlines
- (5) Bushings
- (6) Arresters
- (7) Inert-gas system cabinet
- (8) Fan Mounting
- (9) Ground Bar Detail Drawing
- (10) Current transformer excitation curves
- (11) Transformer Volts/HZ Withstand Capability Curve

**8.04.01** After equipment is completely built per Purchaser's and Manufacturer's specifications, Final "As-Built" drawings shall be produced and supplied to Purchaser as follows:

- (1) Four (4) sets of good quality black-line type drawing prints for each item listed on the Purchaser's purchase order.
- (2) One (1) set of black-line type drawing prints packaged in a weatherproof container and sent with each and every equipment unit ordered.
- (3) One (1) set of drawings in AutoCAD format on CD-ROM properly labeled with all transmittal information. Drawings may be E-mailed to Purchaser if desired.

**8.04.11** All final "As-Built" drawings must be submitted rolled (not folded) and bound in a regular mailing tube, except for 8-1/2 x 11" drawings capable of being placed in an envelope with a cardboard backing. Each of the drawings shall be clearly and conspicuously marked as "As-Built".

**8.04.12** The final "As-Built" drawings shall be forwarded in the most expeditious manner. Final drawings are to be received prior to receipt and payment for the order.

#### **8.05 Instruction Manuals:**

- 8.05.01** The instruction manual shall contain the Purchaser's name, purchase order number and Manufacturer's sales order number and/or shop order number.
- 8.05.02** The instruction manual shall have an index giving the name and identification number of the information bulletins (I.B.'s) contained therein.
- 8.05.03** The I.B.'s shall have complete information on shipping, receiving, installation, operation, and maintenance instructions, as well as renewal parts lists for all parts. Specifically and in addition to the requirements herein, the I.B.'s will include the following:
- (1)** Good schematics for trouble shooting electronic modules, showing how each module is incorporated into the control schematic of the equipment.
  - (2)** Sufficient information for obtaining electronic parts from local sources. Include cross reference to Motorola, Texas Instruments and the like.
  - (3)** Any "O" ring and gasket information such as material, size, lubrication, or adhesive data.
- 8.05.04** Four (4) sets of instruction manuals for each item of the purchase order shall be received by the Purchaser prior to receipt of order.
- 8.05.05** One (1) set of instruction manuals shall be in a weatherproof container and placed in a holding device within the control cabinet of each and every unit listed on the purchase order or subsequent change orders thereto.
- 8.05.06** If instruction manuals are available in an electronic format, these shall be so supplied on CD-ROM in Microsoft Word version 6.0 for Windows format or PDF format.

## **8.06 Supplemental Drawings**

The Manufacturer shall supply one set of drawings and color photographs showing the physical assembly of the transformer's internal components to assist in troubleshooting and/or partial overhaul of the unit.

## **9.00 INSPECTIONS-TESTS:**

### **9.01 Manufacturer**

#### **9.01.01 General**

- (1)** The Purchaser reserves the right to witness all tests and shall be notified at least 10 working days in advance of the tests.
- (2)** Certified test reports for the tests performed shall be transmitted to the Purchaser prior to shipment of the transformer. When requested by the Purchaser, the Vendor shall review the test results with the Purchaser and obtain approval for shipping.
- (3)** Should the transformer fail a specified factory test or show abnormal results, the Vendor shall immediately inform the Purchaser. The cause of the problem and the proposed corrective action shall be discussed with the Purchaser prior to the implementation of corrective actions. After the problem is corrected, the transformer shall be re-tested without any additional cost to the purchaser or Owner. All repair details shall be documented and included in the Test Report.

#### **9.01.02 Factory Tests**

The Manufacturer shall test all items manufactured under these specifications. Any items that do not meet all of the requirements of this specification shall not be shipped to the Purchaser. Such tests shall include the following tests, which shall be performed on the full transformer with all of its appurtenances and accessories (such as bushings, radiators and fans) attached as specified in ANSI C57.12.00 and in accordance with ANSI C57.12.90. Only bushings that are to be supplied and shipped with the transformer shall be used during all tests.

- (a)** Resistance measurements of all windings on the rated voltage connection of each unit and at the tap extremes of one unit of a given rating per order. All measurement readings shall be corrected to 75 degrees Centigrade.
- (b)** Ratio tests on the rated voltage connection and all tap connections with a ratio bridge.
- (c)** No load loss at rated and 110% voltage at the rated voltage connection before and after impulse test.
- (d)** Excitation current values for each phase (not average) at 100% and 110% of rated voltage and at 10 kV before and after impulse test.
- (e)** Load loss at rated voltage and base kVA.
- (f)** Positive sequence impedance at rated current and frequency on a voltage connection of each unit and on the tap extremes of one unit.

- (g)** Zero sequence impedance shall be provided on Wye-Wye connected windings and autotransformer windings.
- (i)** When a transformer is supplied with auxiliary cooling equipment to provide more than one kVA rating, impedance and load loss shall be measured at the lowest kVA rating.
- (h)** Polarity and phase relation tests on the rated voltage connection.
- (i)** Temperature rise tests at maximum forced cooled ratings: Temperature rise tests shall be conducted on all transformers, with group of fans out of service to verify the rating requirement per this specification. Temperature rise tests shall also be conducted to verify the transformer can be safely energized with all cooling equipment out of service to verify the rating requirement per this specification. The Manufacturer shall monitor all four sides and the top of the transformer using Infrared Thermal Imaging technique for hot spots due to induced currents on the tank wall and tank top. Thermal images shall be recorded every hour or frequency deemed by the conditions observed during the Thermal Testing. Images showing extreme or adverse conditions shall be included in the final Certified Test Report. Oil samples shall be taken for gas in oil analysis both before and after temperature rise testing. The maximum increases in the gas levels are as shown:

Hydrogen	10 ppm
Ethylene	1 ppm
Methane	3 ppm
Ethane	3 ppm
Acetylene	Non detectable
Carbon Monoxide	40 ppm
Carbon Dioxide	150 ppm

- (j)** Applied-voltage tests
- (k)** Partial discharge (Corona) tests for all transformers covered by this specification shall be in accordance with IEEE Trial Use Standard 262B. The test is to be made at 150% rated voltage for one hour with 150 micro Volt guarantee.
- (l)** Impulse Tests - ANSI impulse tests.
- (m)** Insulation power factor and resistance measurements shall be performed on all transformers and mentioned accessories delivered with no assumed temperature correction factors.
  - (i)** Insulation resistance measurements shall be performed when the unit under test is at 20 degrees Celsius. The insulation resistance tests shall include the HV to LV and ground, HV to ground, HV to LV, LV to HV and ground, LV to ground, and LV to HV. These tests

shall be performed with instrumentation that includes a guard circuit. Printed test results will be included with certified test results.

- (ii) Insulation power factor tests shall be performed with either “Doble” M2HD or the M4000 test systems. Reports shall be delivered in both the “Doble Test Assistant” version 3.06 (or later) on printed test reports included with the certified test results. The required test and the methods to be followed are stated in IEEE Std. C57.12-90-1993 section 10.10. In Table 4 Method II is the required technique. All transformer winding tests shall be performed at the following top oil temperatures in descending order 70, 60, 50, 40, 30, and 20 degrees Celsius and the test results shall be recorded for each temperature. This will assist the Purchaser in determining a specific temperature correction curve for the transformer. Bushing results are only required to be done at 20 degrees Celsius.
- (n) Control Wiring and Current Transformer Ratio and Polarity Tests to verify all wiring connections and integrity, auxiliary cooling operation and control functions including alarms and annunciation.
- (o) Oil Samples should be taken and analyzed for dissolved gasses before transformer testing, after each heat run, and after each voltage test.
- (p) Induced Voltage Test.
- (q) Radio Influence Voltage Test.
- (r) Audio Test.
- (s) Core to Ground Insulation Resistance Test.
- (t) A tank temperature and gas dew point measurement should be made less than eight hours immediately prior to shipment.
- (u) Sweep Frequency Response Analysis (SFRA) test performed on assembled transformer with oil prior to shipment.
- (4) All test results shall be recorded and made available to the Purchaser. Six sets of certified test data shall be furnished to the Purchaser for each unit. All test documents, including procedures, results, and recordings shall be in English. The Purchaser requests an electronic copy sent via email or on CD, if available.
- (5) If the results of the performance tests show that the equipment does not meet the performance specified, the Manufacturer shall correct the equipment by adjustment, repair, replacement, or addition to the defective equipment so that the equipment will be capable of meeting the performance specified. The cost of materials, shipment, shop labor, and field labor associated with correction of the equipment, including cause,

disassembly, inspection, reassembly, and retest shall be borne by the Manufacturer.

- (6) Except where more stringent industry standard tests are to be performed, all manufacturer's normal quality control tests shall be performed.

### 9.01.03 Field Tests

- (1) Following satisfactory placement of the transformer unit on the destination transformer foundation, the following tests shall be performed with all tests results recorded and made available to the Purchaser:
  - (a) Resistance measurements of all windings on the rated voltage connection of each unit and at the tap extremes of one unit of a given rating per order. All measurement readings shall be corrected to 75 degrees Centigrade.
  - (b) Ratio tests on the rated voltage connection and all tap connections with a ratio bridge.
  - (c) Insulation power factor and resistance measurements shall be performed on all transformers and mentioned accessories delivered with no assumed temperature correction factors.
    - (i) Insulation resistance measurements shall be performed when the unit under test is at 20 degrees Celsius. The insulation resistance tests shall include the HV to LV and ground, HV to ground, HV to LV, LV to HV and ground, LV to ground, and LV to HV. These tests shall be performed with instrumentation that includes a guard circuit. Printed test results will be included with certified test results.
    - (ii) Insulation power factor tests shall be performed with either "Doble" M2HD or the M4000 test systems. Reports shall be delivered in both the "Doble Test Assistant" version 3.06 (or later) on printed test reports included with the certified test results. The required test and the methods to be followed are stated in IEEE Std. C57.12-90-1993 section 10.10. In Table 4 Method II is the required technique. All transformer winding tests shall be performed in accordance with IEEE Std. C57.72-90-1993 Section 10.10. Tests shall be made with temperature of windings and insulating liquid as near the reference temperature of 20°C, as practicable. Tests made at temperatures other than at 20 C shall be corrected in accordance with Table 5 and with formula (25), as shown in IEEE Std. C57.12-90-1993.
  - (d) Control Wiring and Current Transformer Ratio and Polarity Tests to verify all wiring connections and integrity, auxiliary cooling operation and control functions including alarms and annunciation.

- (e) Oil Samples should be taken and analyzed for dissolved gasses before transformer testing, after each heat run, and after each voltage test.
  - (f) Excitation current test to confirm the integrity of the transformer in comparing the measured field test with that done at the factory in accordance with IEEE Standard C57.12.90, Clause 8.
  - (g) Sweep Frequency Response Analysis (SFRA) test performed and compared to same test results made at the factory prior to shipment.
- (2) Any inspection, special testing and correction of the transformer that is necessary due to damage, abnormal impact recorder readings, no positive gas pressure, abnormal core to ground insulation resistance, or PCB contamination will be at the expense of the Manufacturer.
  - (3) All field test results shall be recorded and made available to the Purchaser. All test documents, including procedures, results, and recordings, shall be in English. Electronic copy via e-mail or CD shall be sent to the Purchaser.

#### **9.01.04 Notification of Tests**

The Manufacturer shall notify the Purchaser at least two weeks prior to the beginning of factory tests on the transformer unit(s). A schedule of tests shall be included in this notification.

#### **9.02 Vendor**

The vendor shall assure that all items that have been in the vendor's possession have been inspected and are in compliance with this specification.

#### **9.03 Purchaser**

- 9.03.01** The Purchaser reserves the right to be present to observe any tests or inspections performed on the items. In the event of test failures that require corrective action to the transformer and retesting at a later date, the Manufacturer shall bear all expenses of the Purchaser and Purchaser's representative to attend and witness retests if the witnessing of the retest is desired by the Purchaser. No exceptions to this requirement will be accepted.
- 9.03.02** The Purchaser may test or cause to be tested any item furnished under this specification.
- 9.03.03** The Purchaser will check the entire unit including the gas pressure and any impact recorder(s) for visual evidence of shipping damage within 72 hours after arrival. Otherwise, a representative of the Manufacturer will make this inspection. In either case, the Manufacturer shall notify the carrier of possible concealed damage. A copy of this notice shall be sent to the Purchaser.

## **10.00 SHIPPING:**

### **10.01 Packaging**

**10.01.01** The transformer shall be shipped as nearly assembled as will be allowed by the weight and size limitations of the carrier or the delicacy of an accessory.

**10.01.02** All impact recorders shall remain the property and responsibility of the Vendor.

**10.01.03** The transformer shall be shipped with all bushings removed.

**10.01.04** All parts not attached to the transformer shall be adequately crated and shipped with the transformer in such a manner that the parts will be adequately protected. If radiators are shipped dis-assembled from the transformer, they shall be charged with 99.99% pure dry nitrogen under 2-4 psi positive pressure and pressure-tight seals shall be supplied on all valves, flanges, threaded couplings and openings.

### **10.02 Labeling**

The Manufacturer shall label each shipping container with the following information on a weatherproof label:

- (1)** Manufacturer's name,
- (2)** Description of the item,
- (3)** Catalog number of contents in the package,
- (4)** Purchaser's name,
- (5)** Purchase order number,
- (6)** Destination,
- (7)** Serialized equipment shall have the serial number of the equipment to which it belongs on the label.

### **10.03 Delivery**

**10.03.01** The delivery shall be F.O.B. destination point shown on the Bid Proposal form. Destination would be the designated substation transformer foundation unless specified otherwise. The shipment shall arrive so that it may be unloaded between 8:00 A.M. and 3:30 P.M. Central Time, Monday through Friday, excluding holidays.

**10.03.02** For transformers shipped FOB substation foundation, except for warranty, the Vendor's responsibility for the delivery of the unit shall end when the transformer is fully assembled, filled with oil, set on the Purchaser's substation pad, tested, and certified to be properly connected and ready to be energized. For transformers to be shipped FOB Purchaser's warehouse, except for warranty, the Vendor's responsibility



shall end when the transformer is unloaded and the crane is detached. No payment shall be due the Vendor until the Vendor's responsibility has been fulfilled.

- 10.03.03** Any special tools and devices required for operation, maintenance and disassembly of equipment furnished under this Specification shall be furnished and delivered with the equipment.
- 10.03.04** Oil to be delivered by tank truck to the specified substation location if the transformer is not shipped with oil. It is preferred that the transformer be shipped with oil.
- 10.03.05** For transformers shipped with oil, then the transformer shall filled with 99.99% pure dry nitrogen under 2-4 psi positive pressure and pressure-tight seals shall be supplied on all valves and tank openings. The nitrogen shall have less than 0.5 percent by volume of impurities and less than 0.03 percent by weight of moisture. A gas pressure gauge for checking the nitrogen pressure on arrival and during storage on the site shall be furnished. **The Manufacturer will provide the purchaser with the initial internal positive pressure and oil temperature at which the transformer was charged at the time of shipping.**
- 10.03.06** If the transformer is shipped without oil, then the transformer shall be filled with dry air to a positive pressure and maintained positive throughout the shipping period. Precautions shall be taken to prevent loss of gas due to tampering. The gas pressure gauge shall be installed so that the status of the internal pressure can be readily known upon arrival. The transformer tank shall be labeled with removable labels indicating that the transformer was "Shipped with Dry Air." **\*The Manufacturer will provide the purchaser with the initial internal positive pressure level at which the transformer was charged at the time of shipping.**
- 10.03.07** Delivery shall be made on the required date specified on the Purchaser's Bid Request Information form. Payment will be made per section 15.00 of this specification. Early or late shipment may be allowed only with the written agreement of the Purchaser, but payment will not be made before the required delivery date.
- 10.03.08** Notification correspondence pertaining to deliveries on this order shall be addressed to:  
Refer to Section 10.04.01
- 10.03.09** Notification of delivery shall be a minimum of 96 hours prior to delivery at Purchaser's FOB destination point.

#### **10.04 Notification for Coordination**

**10.04.01** All correspondence pertaining to this order concerning engineering and testing including deliveries shall be addressed to:

**Mr. Don Iles  
Toledo Bend Project Joint Operation,  
450 Spur 135  
Burkeville, TX 75932  
diles@sratx.org**

With a copy to:

**Mr. Greg Grusendorf, P.E.  
Schneider Engineering, LLC.  
191 Menger Springs Parkway  
Boerne, TX 78006  
ggrusendorf@se-texas.com**

**10.04.02** All correspondence shall include the Purchaser's purchase order number and a description of the pertinent items.

**10.04.03** The Manufacturer shall notify Purchaser of:

- (1)** the date unit is to be shipped;
- (2)** the date and expected arrival time, carrier, and freight bill number when applicable;
- (3)** notification 96 hours prior to arrival.

**10.04.04** If transformers are shipped without oil, the notification of the shipment of oil shall be the responsibility of the transformer Manufacturer.

**10.04.05** If Purchaser approves the manufacturer of unit outside the United States, and if units are shipped from outside the United States and are subject to Customs Inspection, the Purchaser shall be notified if the units are to be held for inspection. If the units are to be opened for inspection, the Purchaser shall be notified and the opening shall be delayed until the Purchaser is able to send their representative to witness the opening. If the unit is drained of oil or physically entered for inspection, the unit shall be returned to the manufacturing facility of origin for vapor-phase processing, inspection for internal cleanliness and correct phase to ground clearances and re-performance of applied voltage tests.

### **10.05 Impact Recorder**

Each truck or rail car carrying transformers or transformer parts shall have two (2) manufacturer owned 3-axis impact recorders, one (1) attached to the transformer and one (1) to the truck/rail car bed. The recorder shall be in good working order and capable of recording during the complete shipment period. Malfunctioning or missing recorder will be deemed by Purchaser as if recorder shows high impact reading. Impact acceptance criteria shall not exceed the recommended limits defined in IEEE C57.12.12.2 and 3 G's longitudinal, 4 G's 3-axis.

### **10.06 Demurrage**

**10.06.01** Manufacturer shall be responsible for all demurrage charges for detainment of trucks due to inspection and special testing described in Section 9.01.02 hereinabove, or failure to coordinate as described in Section 10.04 hereinabove.

**10.06.02** Any demurrage charges caused by Purchaser's failure to remove transformer after being properly notified as prescribed in Section 10.04 above, and there is no detainment due to Section 9.01.02 hereinabove stated, shall be the responsibility of the Purchaser.

## **11.00 SERVICING AND ASSEMBLY:**

### **11.01 Service Personnel**

**11.01.01** The services of an authorized service representative to inspect the unit and to assist the Purchaser's personnel in preparing the transformer for service shall be furnished by the Manufacturer at the Manufacturer's cost. All representatives of the Manufacturer shall be fluent in the English language.

**11.01.02** The Purchaser shall notify the Manufacturer at least two weeks prior to the scheduled time for the installation and inspection of the transformer.

**11.01.03** The number of days of service time will vary with the complexity of the individual transformer but in no case shall the time be less than two (2) days.

**11.01.04** This time shall include the core and coil inspection, bushing and radiator installation, vacuum oil filling and testing as required from the condition of the transformer after arrival.

### **11.02 Manufacturer's Requirements**

Any Manufacturer's requirements regarding servicing and assembly shall be stated in the Instruction Manual per Section 8.03 of this specification.

### **11.03 Additional Manufacturer Requirements**

The Manufacturer will be responsible for delivering the transformer to the job site, placement on foundation, and for normal servicing of the transformer. This shall be done at the Manufacturer's expense. Normal service to a transformer shall be:

- (1)** Installation of bushings and surge arresters
- (2)** Installation of radiators and fans
- (3)** Oil filling and processing and Hot Oil circulation, as required
- (4)** Any additional assembly required shall be done at the Manufacturer's expense.
- (5)** Any field testing, if required by Contract.

### **11.04 Insurance Requirements**

Refer to Owner's General Conditions – Section 26

**12.00 APPROVED BIDDER**

**12.01 Approved Bidders**

Refer to Instruction to Bidders

**12.02 Bid Evaluation**

Refer to Instruction to Bidders

**12.03 Experience Clause**

**12.03.01** The Manufacturer shall furnish to the Purchaser a Customer List containing company names and contact information for **ALL** Customers within the state of Texas and Louisiana that have purchased a transformer unit of like design from the manufacturer in the five years preceding the receipt of this Specification. Such list will include, at a minimum, the Customer name, address and phone number along with the Customer contact name on record at the time the transformer was purchased. Such information will be used by the Purchaser in the evaluation of the bids. If the Manufacturer does not have Customers meeting the above criteria, Manufacturer may make an alternate reference list submission with explanation.

**13.00 BID PROPOSAL:**

**13.01** All information requested on the Bid Proposal shall be furnished at Bid Time.

Refer to Bid Packet and Instruction to Bidders

**14.00 REJECTION:**

Refer to General Conditions Sections 15, 16 & 39.

**15.00 INVOICE:**

- 15.01** The invoice issued to Purchaser for items furnished under this specification shall be sent to:  
**Mr. Don Iles**  
**Toledo Bend Project Joint Operation**  
**450 Spur 135**  
**Burkeville, TX 75932**
- 15.02** The invoice shall contain the purchase order number.
- 15.03** No invoice will be paid by Purchaser until complete reception by Purchaser of all items listed on the purchase order at the specified destination, unless otherwise specified.
- 15.04** No invoice will be paid by Purchaser until after Purchaser has completed satisfactory acceptance testing to include Doble (Excitation, Ratio, Power Factor, Bushing Factor), DC Winding, Impedance, and Oil testing. Purchaser will complete acceptance testing within ten working days of Manufacturer having transformer assembled, and Manufacturer and Purchaser having transformer wired to AC and DC voltage sources.
- 15.05** Net payment will be made by Purchaser within 30 days of the conditions in sections 15.03 and 15.04 being met. This payment method will only be changed by mutual written agreement between the Purchaser and supplier.

**16.00 WARRANTY:**

- 16.01** The Manufacturer guarantees that the performance of the equipment supplied will meet the specification requirements included herein relating to design and performance when operated in accordance with generally accepted operating practices of the electric power producing industry. The conditions of any test made or caused by Purchaser shall be as herein specified and the Manufacturer will be notified of, and may be represented at, all tests that may be made.

If the results of the performance tests show that the equipment does not meet the performance specified, the Manufacturer shall correct the equipment by adjustment, repair, replacement, or addition to the defective equipment so that the equipment will be capable of meeting the performance specified. The cost of materials, shipment, shop labor, and field labor associated with correction of the equipment, including cause, disassembly, inspection, reassembly, and retest shall be borne by the Manufacturer.

Any repaired or replacement part furnished under the aforesaid performance guarantee shall carry warranties on the same terms as set forth below.

- 16.02** The Manufacturer warrants that the equipment to be furnished shall be free from design defects that result in equipment failures, defects in material, workmanship, and title; and shall meet all specification requirements included herein. The warranty shall be for a period of five (5) years from the time of delivery. If during the above warranty period the equipment is not available for operation due to failure to meet such warranties, such time of unavailability shall not be counted as part of the warranty period.

During the first 18 months of the period described above, or one year from energization, whichever comes first, the warranty shall cover the costs of removal of the defective transformer or part thereof, any freight be common carrier in full for transporting the unit to and from the place of repair, and reinstallation after repair. Costs of removing structures or associated equipment and special, indirect, or consequential damages will be excluded.

If the equipment delivered hereunder does not meet the warranties specified above, the Purchaser will promptly notify the Manufacturer. The Manufacturer shall thereupon correct any defect, including non-conformance with specifications, except for performance items covered above, at its expense, by repair or by replacement. The cost of field labor associated with repair or replacement, including disassembly, inspection, and reassembly of the equipment, shall be borne by the Manufacturer. Any repaired or replacement part furnished under the aforesaid warranty shall carry warranties on the same terms as set forth above except the warranty period shall be for at least one year from its date of repair or replacement or until the end of the warranty period, whichever period expires later.

The Manufacturer will be held strictly and specifically accountable for the full performance of his products in complete accord with the representations, warranties, and/or affirmations of fact submitted in connection therewith, all in conformance with the applicable laws of the State of Texas and the United States of America.

**All standard commercial terms and conditions of bidders, including warranty conditions, will not be accepted by the Purchaser if they do not meet or they conflict with the minimum requirements of the commercial terms and conditions presented in these specifications.**

**17.00 DISCLAIMER:**

N/A

**18.00 SPARE PARTS:**

N/A

**SPARE PARTS:**

The manufacturer shall provide a spare parts price list for the below mentioned parts.

- a. HV Bushing
- b. HO Bushing
- c. LV Bushing
- d. HV Arrester
- e. LV Arrester
- f. Cooling Fan
- g. Complete gasket set

## APPENDIX A

### GSU TRANSFORMER SPECIFICATION

#### LOSS EVALUATION INFORMATION

1. Losses:

1.01 Each proposal shall provide maximum guaranteed load and no-load loss information in watts. The following loss associated life cycle costs will be evaluated.

- a) No-Load: \$2,850/kW
- b) Load Losses: \$1,810/kW
- c) Auxiliary Losses: \$1,390/kW

1.02 Factory tests that yield losses exceeding those guaranteed by the proposal shall result in a credit to the Purchaser. The credit will amount to the difference between the tested and guaranteed losses using the values in 1.01.

(Actual No-Load Losses – Guaranteed No-Load Losses) x \$2,850

(Actual Load Losses – Guaranteed Load Losses) x \$1,810

(Actual Auxiliary Losses – Guaranteed Auxiliary Losses) x \$1,390

Transformers with losses in excess of 10% of quoted no-load, or total losses that are 6% greater than quoted, are subject to being rejected.



**Appendix B**  
**Equipment Worksheet**  
**Toledo Bend Hydroelectric Generation Substation**

Surge Arresters to be Furnished									
	Manufacturer	Catalog #	Rating (kV)	MCOV (kV)					
High Side Arresters									
Low Side Arresters									
Performance Data – At Base MVA Rating & 75°C									
A. Guaranteed Maximum Losses									
Excitation		% Ex I			No Load kW			Load kW	
100 % V									
110% V									
B. Auxiliary Losses					C. % Regulation			D.% Impedance (H to X)	
MVA		kW			H to X at 100% PF		H to X at 80% PF		H to X
30									
40									
50									
56									
Auxiliary Total Power Requirements									
Forced Cooling		kW		PF		Volts		No. Phases	
First Stage									
Second Stage									
Total Amps:				At DC Volts:					
Bushings to be Furnished									
Bushing	Insulation Class kV	Manufacturer	Catalog #	Type	B.I.L. kV	Min. Creep in.	Draw Lead Yes/No	Potential Tap Yes/No	Spare Furnished Yes/No
H									
H <sub>o</sub>									
X									
Mechanical Data									
Weight in Pounds					Dimensions in Inches				
Core & Coil	Tank & Fittings	Oil Gal/Weight	Total	Height	Width	Depth	Height over Cover	Untanking (plus slings)	
		/							
Additional Transformer Information					Exceptions/Attachments				
<del>Manufacturer</del>		<del>Type of LTC</del>		Maximum Audible dB	Shipped with Oil Yes/No				
<del>Reinhausen</del>		<del>RMV-II</del>							
Delivery (time in weeks)									
FOB Destination:									
Approval Drawings ARO		Approval Drawing Review Period		Final Drawings ARO		Testing to Begin ARO		Shipment from Factory ARO	Arrival at Destination ARO

Proposal Prepared by: \_\_\_\_\_ (Signed)

Name: \_\_\_\_\_

Company: \_\_\_\_\_ Date Prepared: \_\_\_\_\_









# SE\_SRA\_GSU\_Specification -03042021 -ifb - signed

Final Audit Report

2021-03-05

Created:	2021-03-04
By:	Raul Montelongo (rmontelongo@se-texas.com)
Status:	Signed
Transaction ID:	CBJCHBCAABAHAHkrDrHznqjUfPhDvr9bOxOPh6rPkPjda

## "SE\_SRA\_GSU\_Specification -03042021 -ifb - signed" History

-  Document created by Raul Montelongo (rmontelongo@se-texas.com)  
2021-03-04 - 5:07:57 PM GMT- IP address: 72.179.168.197
-  Document emailed to Anup Mazumder (amazumder@se-texas.com) for signature  
2021-03-04 - 5:09:28 PM GMT
-  Email viewed by Anup Mazumder (amazumder@se-texas.com)  
2021-03-04 - 5:53:26 PM GMT- IP address: 216.177.162.74
-  Document e-signed by Anup Mazumder (amazumder@se-texas.com)  
Signature Date: 2021-03-04 - 5:55:00 PM GMT - Time Source: server- IP address: 216.177.162.74
-  Document emailed to Lance Pettigrew (lpettigrew@se-texas.com) for signature  
2021-03-04 - 5:55:02 PM GMT
-  Email viewed by Lance Pettigrew (lpettigrew@se-texas.com)  
2021-03-05 - 3:44:08 AM GMT- IP address: 107.77.199.76
-  Document e-signed by Lance Pettigrew (lpettigrew@se-texas.com)  
Signature Date: 2021-03-05 - 3:44:46 AM GMT - Time Source: server- IP address: 107.77.199.76
-  Agreement completed.  
2021-03-05 - 3:44:46 AM GMT